



CONFEDERATION OF AUTOSPORT CAR CLUBS

Ice Race Regulations

Effective January 1, 2025

Revised January 13, 2025

No express or implied warranties of safety or fitness for a particular purpose shall be intended or result from the publication or compliance with these or any other official regulations.

All rights reserved. This book may not be reproduced in any form or by any means without written permission from the Confederation of Autosport Car Clubs.

Confederation of Autosport Car Clubs
18978 119 Ave
Pitt Meadows, BC V3Y 1X6

www.caccautosport.org



Table of Contents

- 1 Forward4
- 2 Terminology5
- 3 Event Information8
 - 3.1 IceX Event8
 - 3.2 Ice Lapping Event.....8
 - 3.3 Ice Attack Event8
 - 3.4 Ice Race Wheel to Wheel Event8
 - 3.5 General Regulations.....8
 - 3.6 Mandatory Drivers Meeting9
- 4 Insurance.....10
 - 4.1 Event Insurance10
 - 4.2 Coverage10
 - 4.3 Disclosure.....10
 - 4.4 Accident Reports10
- 5 IceX, Ice Lapping and Ice Attack11
 - 5.1 Driver Eligibility11
 - 5.2 Helmet Requirements.....11
 - 5.3 Vehicle Requirements12
 - 5.4 Tire Classifications13
 - 5.5 Car Classifications.....13
- 6 Ice Race Wheel to Wheel.....15
 - 6.1 Driver Eligibility15
 - 6.2 Helmet Requirements.....16
 - 6.3 Vehicle Requirements16
 - 6.4 Tire Classifications18
 - 6.5 Car Classifications.....18
- 7 Tire Specifications.....19
 - 7.1 Rubber.....19
 - 7.2 Street Studs.....19
 - 7.3 Racing Studs19
 - 7.4 Limited Racing Studs20
- 8 Track Design21
 - 8.1 Standards of Course Design21
- 9 Flag Definitions23
 - 9.1 Green Flag.....23



9.2 Red Flag23

9.3 Black Flag with Red/Orange Circle23

9.4 Diagonal Black/White Flag23

9.5 Black Flag.....23

9.6 Yellow Flag23

9.7 Yellow Flag with Red Stripes.....23

9.8 Blue Flag24

9.9 Checkered Flag24

9.10 Ignoring of any Flag.....24

10 Event Safety25

10.1 Sufficient Course Workers.....25

10.2 Communications.....25

10.3 Spectator Safety25

10.4 Safety of Officials25

10.5 Equipment25

10.6 First Aid and Emergency Requirements25

11 Queries, Protests, Appeals and Penalties27

1 Forward

Previous editions of the Ice Race Rule Book as well as all previous CACC Competition Bulletins are superseded by this CACC Ice Race Rule Book. CACC reserves the right to revise these rules, to issue supplements to them, and initiate special rulings at any time in an emergency. Changes to these rules will become effective upon the official issuing of a CACC Competition Bulletin and/or publishing of any changes in the CACC newsletter. Questions concerning rules clarifications should be directed to the CACC Ice Race Director.

The rules and regulations set forth herein were established by the CACC and are intended to assist in the orderly conduct of Ice Race events and to further participant and spectator safety.

The text of these regulations was originally drafted in English and may be translated into other languages. In case of a dispute between the English text and that of any other translation, the English text shall prevail. In this Rule Book, any reference to the masculine shall include the feminine, and references to the singular shall include the plural.

By participation in these events, all participants are deemed to have agreed to be bound by the CACC GCR's and this rulebook. The interpretation and determinations of these rules by CACC officials shall be final and binding. In order to maintain a sporting nature, to achieve prompt competition results, and in consideration of the benefits to them, all members, clubs, and officials of CACC hereby agree that:

- Determinations by CACC officials are non-litigable;
- No litigation shall be initiated against CACC or its members and officials to reverse or modify results of such determinations, or to seek to recover damages or other relief allegedly incurred or required as a result of such determination; and
- Where a person initiates or maintains litigation in violation of this provision, that person agrees to reimburse CACC for all costs associated with the legal action.

2 Terminology

The following definitions are adopted for use in the CACC GCR's, in the Regulations of CACC, in the appendices thereto, in all Supplementary Regulations, and for general use.

| | |
|------------------|--|
| ASN | Canada's National Motorsports Sanctioning Authority recognized by the FIA as the sole holder of the sporting power in a country. |
| AUTOMOBILE | A land vehicle propelled by its own means, running on at least four wheels not in a line, which must always be in contact with the ground and of which at least two must effect steering and at least two the propulsion. |
| CACC | Confederation of Autosport Car Clubs is the governing body for motorsport events in the Province of British Columbia. Its duties and powers include, but are not limited to assuring that Ice Race events are conducted in accordance with this Rule Book. |
| CACC EXECUTIVE | A group of four or more individuals responsible for the administration of and overseeing of the conduct of events, and the enacting of policies as adopted by the membership of the CACC. |
| CLUB | Any body recognized by CACC as a club. |
| COMPETITION | A contest, governed by the CACC GCR's and the applicable event regulations, in which an automobile takes part and which is of a competitive nature or is given a competitive nature by publication of results. |
| COMPETITOR | A person whose entry is accepted for any event or who competes in any event, whether as an entrant or as a driver. |
| COURSE | The route to be followed by a competitor in a competition. |
| DISCIPLINE | All CACC competitions are categorized by type of activity or "discipline" (e.g. Race, Rally, Ice Race, SoloSprint, etc.). |
| DRIVER | A person nominated as the driver of an automobile in any competition. |
| ENTRANT | A person or organization whose entry is accepted for any competition. |
| EVENT | A program of one or more competitions. |
| FIA | Fédération internationale de l'automobile, the international federation of National Automobile Clubs. The governing body for all motoring in the world. |
| ICE ATTACK EVENT | An event on ice /snow in which vehicles run individually (even though two or more may be in motion simultaneously) and in which the relative performance of the competitors is assessed by timing them over a given distance. (Passing is not permitted.) |

| | |
|-------------------------------|--|
| ICE LAPPING EVENT | An event on ice /snow in which vehicles run individually (even though two or more may be in motion simultaneously). The relative performance of the participants is not timed as this is a non-competitive event. (Passing is not permitted). |
| ICE RACE WHEEL TO WHEEL EVENT | An event in which vehicles run as a group on a designated course and results are determined by the first vehicle to cross the finish line within a pre-determined amount of time. |
| ICEX EVENT | An event held on an ice/snow covered closed course with a start and a finish line in which scoring is based on the time taken to complete the course. |
| LICENSE | A certificate of registration issued by CACC or ASN to any person wishing to take part in Ice Race competitions. |
| LICENSED COMPETITOR | Any competitor who has applied for and received a CACC Competition License that is valid for the current competition year. |
| MARKED RACETRACK | Means that portion of a race track that is used by cars for racing and includes the racing surface and the pit lane. |
| ORGANIZER(S) | A person or persons approved by CACC and authorized by promoters, clubs, or other groups to organize an event on their behalf. Where an organizer is appointed to act on behalf of promoters, such organizer shall take the place of such promoters for the purposes of the CACC GCR's and shall be deemed to be the agent of the promoters. |
| ORGANIZING PERMIT | The documentary authority to organize and hold a competition granted solely by CACC. |
| PARTICIPANT | Means any person or body involved at an event as an official, entrant, driver, crew or worker. |
| PENALTY | Means a punishment for breaching a rule or regulation. |
| REGIONAL EVENT | An event which is open to members of any CACC Club which CACC regional permit registered competitors within a Region. |
| REGULATIONS | A set of regulations in addition to the CACC GCR's which may be issued from time to time by CACC to meet particular situations which might arise outside of the CACC GCR's, or to meet a particular problem of a more or less temporary nature. |
| SANCTIONED EVENT | Any event or competition authorized and approved by CACC and having the appropriate organizing permit. |
| START/FINISH LINE | Means the control line on an event course and represents the point at which an event first commences as well as the point at which an event completes. |



SUPPLEMENTAL REGULATIONS Regulations drawn up by the organizers of a competition or competitions and approved by CACC with the object of laying down details of such competitions. These are supplementary to the CACC GCR's and the Regulations of CACC.

3 Event Information

3.1 IceX Event

A CACC sanctioned event held on an ice/snow covered closed course with a start and a finish line in which scoring is based on the time taken to complete the course.

3.2 Ice Lapping Event

A CACC sanctioned event on ice /snow in which vehicles run on a closed circuit with one car at a time. Multiple cars may be on track at one time. Passing in any session is not allowed. Vehicles/drivers of similar speed or ability are grouped together to allow for sufficient spacing such that there is minimal chance of one vehicle catching another on course during the session. Participants are required to possess a valid driver's license as enumerated below.

3.3 Ice Attack Event

A CACC sanctioned event on ice /snow in which vehicles run a speed competition on a closed circuit with one car at a time running against the clock for fastest time. Multiple cars may be on track at one time. Passing in any session is not allowed. Vehicles compete against the clock one at a time or at sufficient spacing such that there is minimal chance of one vehicle catching another on course during the timed competition. Competitors are required to possess a valid competition license as enumerated below.

3.4 Ice Race Wheel to Wheel Event

A CACC sanctioned event in which cars run as a group on a designated surface; where racing speeds are attained; where maximum safety protection is afforded to the spectators and property; and in which competitors are required to possess a valid competition license as enumerated below.

3.5 General Regulations

The regulations contained in this section shall apply to all IceX Events, Ice Lapping Events, Ice Attack Events and Ice Race Events held in British Columbia. They were designed to assist in ensuring a safe and enjoyable event. The regulations contained in this section are the minimum acceptable requirements that must be adhered to in all CACC sanctioned IceX Events, Ice Lapping Events, Ice Attack Events and Ice Race Events and must also fully comply with the regulations contained in the CACC General Competition Rules. Organizers of IceX Events, Ice Lapping Events, Ice Attack Events and Ice Race Events may elect to specify more comprehensive regulations as necessary.

- 3.5.1 The waiver must be signed by everyone. Anyone under the age of eighteen (18) must sign a "minor consent" waiver each race weekend and have a "parental consent" form signed one time by both parents/guardians prior to receiving permission to race or work a race event.
- 3.5.2 There must be a **minimum of 8 inches of ice** on or near the racing surface as measured and recorded at regular intervals throughout the day.
- 3.5.3 All due caution for environmental protection is to be taken while handling toxic products in the pits. Littering or fluid spills by any person on or around the race venue may result in the exclusion of the driver and will leave persons so doing, open to charges under the Fish and Wildlife Protection Act.

- 3.5.4 There will be no alcohol/controlled substance consumption at the race venue. Any alcohol/controlled substance consumption will result in the exclusion of the entrant from the entire weekend.
- 3.5.5 The organizer(s) reserves the right to refuse entry.

3.6 Mandatory Drivers Meeting

- 3.6.1 Instructions to Competitors: The organizer will call all competitors to a Driver's Meeting prior to the start of the event. All competitors are required to attend this meeting. The Organizer shall cover the following topics:
- Introduce the event officials.
 - Review the course diagram/track layout, and procedures.
 - Make sure all entrants have signed the waiver
 - Describe any penalties to be assessed.
 - Review supplementary regulations, run groups, gridding, flagging, work requirements (marshaling).
- 3.6.2 Organizers should have a system in place to verify attendance at the Driver's Meeting, to avoid uninformed participants on the course/track.

4 Insurance

General Liability Insurance is provided under the CACC insurance plan. All CACC affiliated clubs must be covered by this minimum level of insurance. The policy protects CACC, the affiliated club, property owners, workers and sponsors against claims for injury or property damage brought against them by the general public. A CACC Affiliated club purchasing the annual policy will have all coverage for a twelve-month period, March 1st through April 30th. For insurance coverage under the CACC master plan, clubs must apply directly to the CACC for Affiliation. Affiliation with the CACC and General Liability Insurance under the CACC plan are mutually inclusive. The term for CACC Affiliation is January 1st through December 31st.

4.1 Event Insurance

Clubs organizing and hosting IceX Events, Ice Lapping Events, Ice Attack Events and Ice Race Events must apply for and receive an Event Permit from CACC and must apply for and receive appropriate Event Insurance from CACC.

4.2 Coverage

All competitors, officials, and workers will be covered against damage to third parties but will be responsible for any deductible amounts. All competitors, officials, workers, and all other persons who are permitted to enter areas normally closed to the general public must sign the insurance waiver before being allowed to participate in the event. Originals of the waiver are available from the CACC Executive Office. Property owners or sponsor names may be added to the club insurance certificate upon request.

4.3 Disclosure

The organizing club of an event must ensure that the Event Permit and Insurance Certificate are posted at the event.

4.4 Accident Reports

All accidents must be reported by forwarding a completed accident report form to the CACC Executive Office within forty-eight (48) hours of the conclusion of the event. The accident report form, available from the CACC Executive Office, should contain as many details as possible, including names and addresses of injured parties and witnesses, medical treatment provided, etc. The accident report form must be completed for all accidents whether or not a claim is anticipated.

5 IceX, Ice Lapping and Ice Attack

5.1 Driver Eligibility

- 5.1.1 Be a Member in Good Standing of the WCIRABC Cars on Ice club or other CACC affiliated club.
- 5.1.2 Hold a current and valid Provincial or State Driver's License with minimal "N" (novice) status.
- 5.1.3 **IceX Only:** New Drivers with "L" or Learner's status may participate but will require a passenger 25 years of age or older with a valid Driver's license at all times when on track.

Ice Attack Additional Requirements

- 5.1.4 **Previous experience in IceX, Ice Lapping, Ice Attack and/or Wheel to Wheel Ice Racing or proof of equivalent experience is required. Proof of previous competition experience may be requested by officials.** Any person who has not competed in at least 1 full ice event within the past 5 years must participate in an IceX event prior to competing in an Ice Attack event.
- 5.1.5 The minimum competitor licensing requirement is as listed below. Please note that the following list of licenses can be either a "novice" or "senior" grade:
 - Canadian Residents – a valid CACC Ice Race or equivalent license issued by ASN for Canada or another of its territories.
 - U.S. Residents – a valid SCCA Track Trials (Solo 1), Regional, National or Pro race license, or equivalent license issued by another ACCUS member.
 - Others – FIA International license issued by your ASN, accompanied by a letter of permission.

5.2 Helmet Requirements

- 5.2.1 All drivers and passengers must wear helmets on course conforming to either the latest or two immediately preceding Snell Memorial Foundation standard or bear an approval sticker of an ASN affiliate of a foreign country. The following standards are acceptable:
 - 5.2.1.1 Snell Foundation 2015 M or SA 2015 or later.
 - 5.2.1.2 SFI Foundation - 31.1A, 31.2A or 31.1/2005
 - 5.2.1.3 British Standards Institution - BS 6658-85 type A/FR
 - 5.2.1.4 FIA 8860-2004 and beyond
- 5.2.2 **Snell 2015M rated helmets are not acceptable for vehicles equipped with a roll cage.** These drivers require a helmet which meets one of the FIA, Snell SA, SFI or BSI standards listed above.
- 5.2.3 Frontal Head Restraint Devices as per current CACC General Competition Rules, are strongly recommended.

5.3 Vehicle Requirements

5.3.1 All vehicles must be in a safe condition and pass an inspection to be conducted prior to the competition aspects of the event. All items in this section are to be inspected to ensure the vehicle meets all requirements without exception and are subject to the approval of the scrutineer at each event.

5.3.2 **Minimum Standards:** To qualify as eligible to participate in an IceX, Ice Lapping or Ice Attack event, each vehicle must comply with the following minimum requirements:

5.3.2.1 It must have four road wheels, not in a line, a minimum of two of which must be driven.

5.3.2.2 It must have a braking system that works on all four wheels simultaneously.

5.3.2.3 It must have a structure and bodywork that surrounds and protects the driver, at least to his waist level when seated in his normal driving position.

5.3.2.4 It must have a minimum wheelbase of 152 cm (60 in.), a minimum front and rear track of 107 cm (42 in.), and a minimum wheel diameter of 25.4 cm (10 in.).

5.3.2.5 Vehicles with a high center of gravity and a narrow track must be excluded. If the vehicle is taller than it is wide, it is not acceptable for competition. Extra caution should be exercised with non-traditional vehicles. The measurements are to be taken from the ground to the tallest point of the vehicle for Overall Vehicle Height and the track measurement from outside of tire to outside of tire on the same axle for the Track Width.

5.3.2.6 Each vehicle should be checked by the competitor prior to presentation for technical inspection. During technical inspection, scrutineers may verify compliance with any of the following:

- **Brakes** – The brake pedal has a solid feel and does not sink to the floor. Brake fluid (and clutch where applicable) must be sufficient in the master cylinder reservoir and no leaks present when the system is pressurized. Brakes must operate on all four wheels
- **Throttle** – Throttle return is positive. Where the throttle is electronic, the vehicle must demonstrate throttle return.
- **Engine Compartment** – engine compartment is in good working order. All cars shall have coolant recovery systems. Where OEM systems have been removed, approved minimum one litre catch tanks for all fluids must be used. Belts and hoses are in serviceable condition. There are no excessive fluids (oil, water, brake) present or leaking.
- **Loose items** – There are no loose items in the interior of the vehicle. Driver's floor mat has been removed or relocated so that it cannot interfere with the operation of the pedals.
- **Road Wheels** – The wheels are securely fastened with all studs/nuts present and functional. Wheels may not be reversed such that the lug hole taper does not mate with the nut/bolt. Wheels may not have missing spokes or cracks in the cast/forged units. Hubcaps, wheel discs and trim rings that are not bolted, or otherwise permanently attached to the wheels are removed. Wheel bearings and suspension components are functional and in good operating condition suitable for auto slalom event conditions.

- **Steering and Suspension** – Steering system does not display any evidence of excessive wear or free play when the steering wheel is turned.
- **Batteries** – Batteries are securely mounted and have the positive terminal insulated with a non-conductive material. Wet cell batteries moved outside the engine compartment from their original location are housed in a non-conductive marine type container and secured to the chassis or structure independent of the container. NOTE: This would allow the use of gel-cell batteries without requiring the marine type container.
- **Roll-over Protection** – Ice Lapping and Ice Attack Only (recommended for IceX) - Rollover protection is required for all open cars (convertible top). All rollover protection devices shall be constructed to the requirements outlined in the CACC GCR. The roll bar or roll cage height may be reduced to the highest possible height which fits within an installed factory specified hardtop or convertible top.
- **Window Requirements** – The driver's window must be either fully rolled up or fully rolled down when the car is on the racecourse. A window net or arm restraints are recommended when the driver's window is fully down.
- **Driver Restraints** – All vehicles must be equipped with a minimum factory 3-point seat belt and drivers and passengers must wear the belts securely fastened while on course. The minimum width of all belts is two inches. The material of all straps shall be Dacron or nylon and in new or good condition.
- **Tow Hooks** – All vehicles must have adequate front and rear towing points. This includes factory bolt on tow hooks.
- **Head / Tail Lights** – All vehicles must be equipped with functioning head lights and tail lights. They must be illuminated while on track.
- **Windshield and Wipers** – All vehicles must be equipped with functioning windshield wipers (minimum 1 on the driver's side). Windshields must be clear of cracks or decals that will obstruct the driver's full view of the track.

5.4 Tire Classifications

*See section 7 for tire specifications.

5.4.1 IceX

- 5.4.1.1 Rubber
- 5.4.1.2 Street Studs

5.4.2 Ice Lapping and Ice Attack

- 5.4.2.1 Rubber
- 5.4.2.2 Street Studs
- 5.4.2.3 Racing Studs

5.5 Car Classifications

- 5.5.1 2WD – 2 Wheel Drive vehicles
 - 5.5.1.1 Front wheel drive



5.5.1.2 Rear wheel drive

5.5.2 AWD / 4WD - All-Wheel Drive vehicles / 4 Wheel Drive vehicles

6 Ice Race Wheel to Wheel

6.1 Driver Eligibility

Any person sixteen (16) or older who is the holder of a valid provincial driver's license, which includes those designated "L" or "N", is eligible to apply for a CACC Ice Race License.

Any person who wishes to compete in an Ice Race Event must complete a "Self-Declaration Medical Form". No doctor appointment is required.

6.1.1 Novice Driver Requirements

- 6.1.1.1 Be a Member in Good Standing of the WCIRABC Cars on Ice club or other CACC affiliated club.
- 6.1.1.2 Must possess a current CACC Novice Ice Race Competition License
- 6.1.1.3 Each host club will appoint a Novice Program Director who will oversee all aspects of the Novice Training Program under the supervision of the Ice Race Discipline Director.
- 6.1.1.4 The Novice Training Program may consist of:
 - 6.1.1.4.1 A written motor sport knowledge test.
 - 6.1.1.4.2 On track training with senior driver in chosen tire group.
 - 6.1.1.4.3 Practice sessions for Novices only in chosen tire group.
 - 6.1.1.4.4 May participate in Senior races held throughout the season (at the discretion of the Novice Director).
- 6.1.1.5 Novice driving competition vehicles must display an ICBC "N" on the rear of their car. "N" will be provided by the Novice Program Director.

6.1.2 Senior Driver Requirements

- 6.1.2.1 Be a Member in Good Standing of the WCIRABC Cars on Ice club or other CACC affiliated club.
- 6.1.2.2 To upgrade from a Novice licence to a Senior licence, a licensee must successfully complete the CACC Ice Race Novice Program.
- 6.1.2.3 A senior driver shall be any driver who has held a CACC Senior Ice Race Competition License in the past 5 years and competed in a minimum of two (2) complete Ice Race Wheel to Wheel events. (Proof of previous competition must be provided by the entrant). If there have been no sanctioned Ice Race Wheel to Wheel events within the previous 5 years, the licensed driver will be under observation by the Steward and Novice Director.
- 6.1.2.4 Must possess a current CACC Senior Ice Race Competition License

6.2 Helmet Requirements

- 6.2.1 All drivers and passengers must wear helmets conforming to either the latest or two immediately preceding Snell Memorial Foundation standard or bear an approval sticker of an ASN affiliate of a foreign country. The following standards are acceptable:
 - 6.2.1.1 Snell Foundation – 2010 or 2015 SA, 2010 SAH.
 - 6.2.1.2 SFI Foundation - 31.1A, 31.2A or 31.1/2005
 - 6.2.1.3 British Standards Institution - BS 6658-85 type A/FR
 - 6.2.1.4 FIA 8860-2004 and beyond
- 6.2.2 Snell 2015M or 2010M rated helmets are not acceptable for vehicles equipped with a roll cage. These drivers require a helmet which meets one of the FIA, Snell SA, SFI or BSI standards listed above.
- 6.2.3 Frontal Head Restraint Devices as per current CACC General Competition Rules, are strongly recommended.

6.3 Vehicle Requirements

All vehicles must be in a safe condition and pass an inspection to be conducted prior to the event. All items in this section are to be inspected to ensure the vehicle meets all requirements without exception and are subject to the approval of the scrutineer at each event.

If a race vehicle does not comply with one or more of the preparation/safety requirements the Technical Inspector, in consultation with the Clerk of the Course may or may not let the vehicle compete. The Technical Inspector will give the vehicle owner or driver the list of deficiencies in writing. If the Technical Inspector permits the vehicle to compete that weekend, ALL deficiencies MUST BE fixed before the vehicle can compete in the next race weekend.

If the Technical Inspector, or his/her designate, checks a vehicle immediately after a race and it is found to be in violation of any of the rules, the driver shall lose any points awarded in that race.

Preparation and Safety Rules

It is recommended to read the CACC General Competition Rules for exact data when constructing a new vehicle.

- 6.3.1 5 point seat belts as per the CACC GCR's.
- 6.3.2 Roll cages complying with CACC General Competition Rules are required.
- 6.3.3 All batteries, not in stock location, must be mounted to the car and enclosed. (Note: the battery must be securely mounted to the car, ie: seat belts are not adequate).
- 6.3.4 All cars must have a substantial firewall between engine and driver.
- 6.3.5 All cars must have operational four wheel brakes.
- 6.3.6 Operational and visible headlights or driving lights, red tail lights and red brake lights are mandatory. LED lights are recommended for tail and brake lights.

- 6.3.7 All tail lights must be mounted on the exterior of the vehicle. An 1156/3156 or equivalent wattage bulb is required.
- 6.3.8 A combination brake/running light mounted high on the rear of the vehicle is mandatory. An 1157/3157 or equivalent wattage bulb is required.
- 6.3.9 Brake lights must be operational and RED. An 1157/3157 or equivalent wattage bulb is required for the combination brake/running light mounted high on the rear of the car is mandatory.
- 6.3.10 Functional inside and outside rear-view mirrors are mandatory.
- 6.3.11 All ballast must be contained and secured with metal to metal fasteners.
- 6.3.12 Maximum sound output for each vehicle is 105dB.
- 6.3.13 Windshield wipers must be operational on the driver's side of the car. Adequate eye protection must be worn by all drivers in vehicles which do not have legal windscreens.
- 6.3.14 Bumpers: No protruding sharp objects. Bumpers to be stock or stock appearing or may be constructed of any material so as to replicate appearance and design of a stock bumper. All bumpers, whose design necessitates it, must have substantial end caps (ie: a piece of tire bolted to the bumper and the fender).
- 6.3.15 Race cars may not exceed a wheelbase of 112 inches.
- 6.3.16 Catch tanks for engine vents are mandatory as follows: 1 x 1 litres for oil and 1 x 1 litres for water OR 1 x 2 litres for both oil & water.
- 6.3.17 It is recommended that a fire extinguisher with a minimum 5BC rating and gauge be mounted securely in the car with a metal strap. (NOTE: fire extinguishers must be certified upon purchase and re-certified every two years and/or after each use.)
- 6.3.18 All vehicles must have adequate **and clearly marked**, front and rear towing points.
- 6.3.19 A window net must be fitted, or the driver's window must be rolled at least halfway up when the car is on the race course.
- 6.3.20 Mud flaps are recommended behind each rear wheel for all vehicles, as well as both front wheels in front wheel drive or all-wheel drive vehicles. Mud flaps must cover the entire tread face of the tire and reach to within three (3) inches of the ice surface without touching the ice surface when the vehicle is static on its racing tires and in racing trim. Mud flaps must be made from a material that will effectively prevent sailing.
- 6.3.21 **Environmentally sensitive anti-freeze is mandatory in all competition vehicles** (ie: propylene glycol).
- 6.3.22 White cars must have significant contrasting colors or marking to ensure their visibility.
- 6.3.23 Competition numbers must be clear and HIGHLY CONTRASTING digits must be displayed on both sides on both front doors (placement to be in the center of each door) of each competition vehicle. Such digits shall be no smaller than 10" high and 1.5" wide and shall be in a solid colour on a solid background of a significantly contrasting colour.



6.4 Tire Classifications

- 6.4.1 Rubber
- 6.4.2 Street Studs
- 6.4.3 Racing Studs

6.5 Car Classifications

- 6.5.1 2WD - 2 Wheel Drive vehicles (front or rear wheel drive)
- 6.5.2 4WD - 4 Wheel / All-Wheel Drive vehicles

7 Tire Specifications

All tires MUST be in good condition, having no cord or blemishes showing. Tread depth must be a minimum of 3.5mm or 5/32".

7.1 Rubber

7.1.1 Any brand DOT street legal snowflake rated tire. 

7.2 Street Studs

7.2.1 Any brand DOT street legal snowflake rated tire  with DOT approved studs, up to and including 35 per linear foot. MUST meet TSMI specifications for the tire.

7.3 Racing Studs

7.3.1 Any brand tire with Stud or Screws are permitted.

7.3.2 Stud Type

7.3.2.1 May have up to 28 studs per linear foot of running surface.

7.3.2.2 Shall conform to diagram figure 1.

A: Maximum height protruding from tread of tire = 7.5mm

B: Maximum shank/shoulder diameter = 10mm

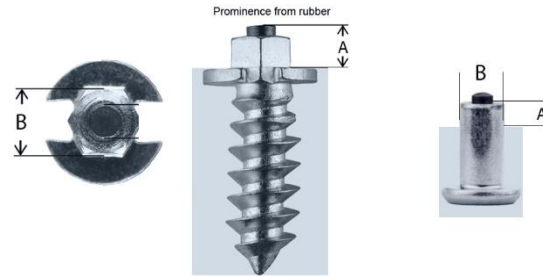

Figure 1

7.3.3 Screw Type

7.3.3.1 May have up to 45 hex washer head screws per linear foot of running surface and can be plain or slotted.

7.3.3.2 Screws may protrude through the inside of the carcass and they may be fastened.

7.3.3.3 Screws must be installed with the hex head pointing outwards.

7.3.3.4 Screws must be 1/4" hex heads and no additional washers or spacers are permitted.

7.3.3.5 Shall conform to diagram figure 2.

| | | | |
|----|------|----|------|
| A. | .250 | H. | .145 |
| B. | .375 | L. | Free |
| D. | Free | U. | .035 |

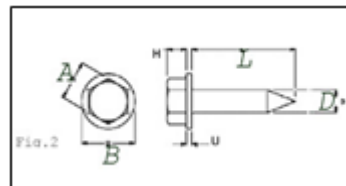

Figure 2

7.4 Limited Racing Studs

- 7.4.1 Limited race studs are to be used only in CACC- Ice X, ICE LAPPING, ICE ATTACK events.
- 7.4.2 These limited race stud rules may be used at the discretion of each club but only with a minimum ice thickness of 12 inches.
- 7.4.3 OPTION A
 - 7.4.3.1 Maximum stud dimensions: 5/16-18 threaded bolts (or M8x1.25), 1.25 inches long (31.75mm). Metal studs of any type smaller than this will still be counted as studs, including screws through the tire.
 - 7.4.3.2 Maximum limited race stud count per tire is 175 studs

| Minimum Tire tread depth* | Bolt Size (US) | Bolt size (metric) | Bolt length*** (L) (SAE/US) | Bolt Length*** (L) (metric) |
|---------------------------|----------------|--------------------|-----------------------------|-----------------------------|
| Greater than 8/32nds | 5/16-18 | M8x1.25 | 1.25" | 32mm |
| Less than 8/32nds** | 5/16-18 | M8x1.25 | 1.00" | 25.5mm |

* Minimum Tire tread depth is defined as the tread depth where on the tire the tread depth is smallest.

** For this calculation, Hoosiers or any other slick tires will be regarded as tires with under 8/32nds of tread

***Bolt length refers to the dimension L in the following print:

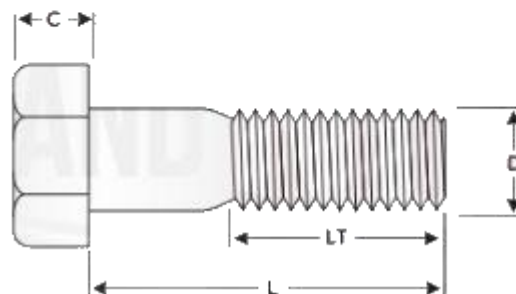
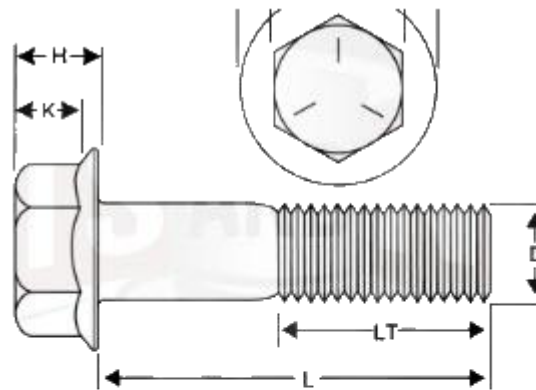

- 7.4.3.3 This is intended to maintain a maximum stud exposure into the ice of ~14mm. Tech and organizers maintain the right to ban tires outside of the targeted envelope, regardless of construction.
- 7.4.3.4 Bolts may be sharpened.
- 7.4.4 OPTION B
 - 7.4.4.1 MF44 Endurance II
 - 7.4.4.1.1 Head socket: 1/4" Hex (6.35mm)
 - 7.4.4.1.2 Head height: 0.33" (8.4mm) (Washer thickness included)
 - 7.4.4.1.3 Washer diameter 1/2". (12.70mm)
 - 7.4.4.1.4 Mechanical tread: 10/32"
 - 7.4.4.1.5 Screw use nylon insert lock nut inside of the tire



8 Track Design

The following standards of course design are provided to give organizers proper direction in designing or choosing a course and also to ensure that adequate safety precautions are in place.

8.1 Standards of Course Design

- 8.1.1 Organizers are cautioned that participants in IceX, Ice Lapping, Ice Attack and Ice Race events are not covered by the participant's own vehicle insurance; appropriate precautions, therefore, must be taken.
- 8.1.2 Organizing an event that complies with these regulations requires prudent good judgment, and common sense. The protection of life and property shall be the prime factor governing all decisions relating to course design and safety.
- 8.1.3 Caution and proper attention must be given to the location of property that might be subject to damage, or cause damage, in the event of loss of control of a vehicle.
- 8.1.4 Events that require the competitor to leave the car during a timed run or require the competitor to start the timed run from outside the vehicle, are not permitted.

- 8.1.5 Pylons may be used to mark unsafe track areas, such as wet or muddy apexes, broken track surface, etc. The installation of chicanes may be used to increase safety margins at certain points in the course. A series of time penalties should be elaborated for knocking over these marking cones or failure to follow the chicanes.
- 8.1.6 IceX, Ice Lapping and Ice Attack Events
- 8.1.6.1 The running of more than one vehicle at a time is permitted, providing the vehicles are separated on the course by adequate time and distance to eliminate the possibility of a passing or a crossing situation.
- 8.1.6.2 The inner and outer limits of turns and corners should be marked by course markers, displacement of which results in time penalties.
- 8.1.6.3 All portions of the course shall be visible to at least one course marshal who can communicate through signals or by electronic means with the starting line.
- 8.1.6.4 Extreme care shall be taken in the location of the start, finish, staging, and timing areas. The timers and staging area must be placed well clear of the course in a safe area. The finish section and course exit should be clearly and carefully defined to safely restrict speeds. It is not recommended that competing cars be required to come to a complete stop immediately following the finish line. It is preferred that cars be required to slow to a walking speed within a controlled area before returning to the grid or paddock areas. A complete stop should be required only when unusual site conditions exist. In all cases, a sufficient distance past the finish line must be available to safely slow or halt any competing car from the highest possible speed attainable at the finish without locking brakes or wild maneuvering. It is recommended that an official be assigned to control the finish area. Particular care must be exercised in the finish area to keep it free from hazards to participants and non-participants.
- 8.1.6.5 All course finishes shall be constructed either in the form of a stop box such that the competitor must come to a full stop before leaving the stop box or with sufficient distance that the competitor can slow to a walking speed within a controlled area before leaving the finish area via the direction indicated by the pylons. In all cases, a sufficient distance past the timing line must be available to safely slow or halt any vehicle from the highest possible speed attainable at the timing line without locking brakes. The finish area must also be pointed away from all spectator, parking, and staging areas.
- 8.1.6.6 Entrance and exit lanes shall enter the course at separate points, though they may be close together. They will be kept clear for use by competing cars at all times.

9 Flag Definitions

9.1 Green Flag

Go; used by the starter and corner marshals to indicate that the track is clear.

9.2 Red Flag

A red flag shown at the start/finish line and simultaneously each corner post informs the driver that a track session has been halted. Drivers shall slow immediately and proceed directly to the pits with no passing.

9.3 Black Flag with Red/Orange Circle

With car number displayed – “Meatball” – informs driver of a mechanical problem likely to cause danger. Reduce speed and PROCEED TO THE PITS where you will be advised of the problem.

9.4 Diagonal Black/White Flag

Car number displayed “Bermuda” Diagonal Black & White Flag with– warns driver of unsportsmanlike or unsafe conduct and that a penalty may be pending. Flag will only be shown once as a warning. Any subsequent infractions will be dealt with using the black flag.

9.5 Black Flag

“Full Black Flag with car number displayed” – finish the current lap, then report immediately to a pre-designated location for instructions.

9.6 Yellow Flag

Any yellow flag is a signal of danger of any nature at, or beyond the station displaying the flag.

- 9.6.1 Standing Yellow – take care, danger, slow down. No passing from the flag until past the emergency area(s). Once the emergency area(s) is passed and the driver can see that there is no yellow flag displayed at the next station, racing may resume.
- 9.6.2 Waving Yellow – great danger, SLOW DOWN, be prepared to stop. No passing from the yellow flag until completely clear of the emergency area(s). Once clear of the emergency area(s) and the driver can see that there is no yellow flag displayed at the next station, racing may resume.
- 9.6.3 Full Course Yellow – (shown as double yellows) great danger, SLOW DOWN, no passing, be prepared to line up single file behind the pace car. Once the emergency area(s) or problem is cleared, the pace car will leave the track and the starter will display a green flag for racing to resume.

9.7 Yellow Flag with Red Stripes

Standing – take care, used to indicate debris on track (tires, pylons, car parts, etc.)

9.8 Blue Flag

9.8.1 Standing Blue – watch your mirrors, another competitor is following very closely.

9.8.2 Waving Blue – watch your mirrors, a faster competitor is trying to overtake and/or pass you.

9.9 Checkered Flag

The race is over. Once receiving this flag, racing must stop, all drivers slow down and complete one more lap, then return to the pit area.

9.10 Ignoring of any Flag

May result in the competitor being excluded from the race, the weekend, the series and/or loss of series points, ***at the discretion of the Steward of the event.***

10 Event Safety

10.1 Sufficient Course Workers

There must be adequate course workers to oversee all competition and to ensure equality and safety to all competitors as determined by the Steward and/or Clerk of the Course.

10.2 Communications

A reliable communication system linking all flagging stations with the clerk of the course shall be established.

10.3 Spectator Safety

It is important that the spectator viewing areas and the spectator parking areas be kept a safe distance from the course. Course security is a must at all times. Uninformed and misguided spectators are to be expected, and adequate crowd control provisions must be made to avoid their unwanted and dangerous wanderings onto the course area.

10.4 Safety of Officials

Full consideration must be given to safety in the pits, around the start/finish areas, and near the flag stations. Particular attention must be given to assuring that timekeepers and course workers are not placed in hazardous locations.

10.5 Equipment

The organizer must provide each marshal station and the start/finish area with the appropriate blue, yellow, red, and red-striped yellow flags. The start/finish area must also be provided with a full set of flags. These flags shall be used to communicate with the drivers when they are on the course, and all workers must be trained in their proper use.

10.6 First Aid and Emergency Requirements

The following minimum emergency safeguards must be in effect at all times during an IceX, Ice Lapping, Ice Attack or Ice Race competition, including driving instruction sessions.

- 10.6.1 At least one fully equipped first aid kit must be present and available.
- 10.6.2 At least one first aid attendant must be on duty and readily available at all times. Said attendant must be currently certified by St. John Ambulance or equivalent, as qualified to perform cardiopulmonary resuscitation. Other attendants must be currently certified by St. John Ambulance or equivalent, as having Standard First Aid training.
- 10.6.3 At least one vehicle solely reserved for the transport of an injured person must be available at all times.
- 10.6.4 A minimum of one five pound 10BC dry-chemical fire extinguisher must be provided at each Marshall station, the start/finish area, and in the pits, all with capable operators. 10BC foam-type extinguishers may also be used to replace the dry-chemical extinguishers.



- 10.6.5 The organizer must elaborate a prearranged safety plan to cope with major emergencies. The organizer must appoint one person to contact Emergency Medical Services via phone and must prepare instructions and directions describing the best route to the site. No others should make emergency calls.



11 Queries, Protests, Appeals and Penalties

All queries, protests, appeals and penalties shall be administered as outlined in the CACC General Competition Rules.